

# Gooch & Housego



**High Power 2 Channel RF Driver:  
For 2 Acousto-optic Q-Switches**

**MQH0XX-YYDM-ZZZ-2S**

**Former Model Number:**

**390XX-YYDMZZZ-2CH-A**

## Description:

The **MQH0XX-YYDM-ZZZ-2S** module is a High Power RF Driver with two RF outputs derived from one oscillator and is designed to drive two Q-Switches. There are two digital modulation control inputs: Fixed and Variable. These controls allow the customer to issue a pulse command of a "Fixed" pulse width, the duration determined by the Driver's pulse width control, settable by the customer, or issue a "Variable" pulse command, the duration determined by the input signal's pulse width. The output power of both channels are controlled by the analog input, where the mode of operation is defined by ZZZ = A05 normal analog mode, or R05 analog switched to full RF mode or a triggered RF Ramp Down mode where ZZZ = FPS first pulse suppression mode or PPK pre-pulse kill mode. The choices of Frequency (XX), Output Power (YY), and Power Control (ZZZ) option are "Factory Set" when ordered. The driver requires forced air cooling.

The product delivered will be manufactured to be compliant with EU Directive 2002/95/EC for Reduction of Hazardous Substance. The product will be manufactured to other standards upon customer request.

## Key Features:

- 24, 27.12, 40.68, 68, or 80 MHz RF Frequency (XX)
- 0.01% Quartz Stabilized
- 2 Outputs with up to 50 watts RF power output (YY) per channel (2S)
- Two TTL Digital Modulation Inputs: fixed and variable pulse width.
- Up to 100 kHz pulse rate.
- Analogue Modulation or Triggered RF Ramp Down Mode (ZZZ)
- Fault Protection on Low Power, High Power, and High VSWR
- Operates on 28 VDC

## Applications:

- RF Driver for an Acousto-Optic Q-Switch Device used spoiling the "Q" of a CW laser so as to output an intense pulse of light.
- Used in industrial, medical, or military applications.

For More Information, Contact: [sales@goochandhousego.com](mailto:sales@goochandhousego.com) [www.goochandhousego.com](http://www.goochandhousego.com)

As part of our policy of continuous product improvement we reserve the right to change specifications at any time.

**MQH0XX-YYDM-ZZZ-2S**
**SPECIFICATIONS**
**PARAMETER:**
**SPECIFICATION:**

Number of Channels	2 Outputs	(RF Power Split from One Oscillator.)
Output Frequency:	<b>XX</b> = 24, 27, 41, 68, or 80	Where RF Frequency = 24.00, 27.12, 40.68, 68.00, 80.00 MHz $\pm$ 0.01%
Spurious Levels:	-50 dBc maximum	
Harmonic Distortion	-30 dBc maximum	
Digital Inputs:	<u>Modulation Common to Both Outputs.</u>	
Fixed Mod In	TTL Levels, Triggered on Rising Edge. Pulse Width Applied >50 ns.	
Variable Mod In	TTL Levels, TTL HIGH = RF off	
Extinction Ratio:	35 dB minimum	
RF Rise Time 10% to 90%	500 ns maximum	
RF Fall Time: 90% to 10%	100 ns maximum	
Modulation Repetition Rates:	1 Hz to 100 kHz for Fixed Modulation DC to 100 kHz for Variable Modulation	
Fixed Modulation	Output Pulse Width Adjustment Range: 1 to 14 ms, Customer Adjustable	
Available Pulse Control Options:	<b>ZZZ</b> = Mode	
Pulse Control Mode is " <u>Factory Set When Ordered</u> ":	FPS = First Pulse Suppression	See Figure 2
	PPK = Pre Pulse Kill	See Figure 3
	A05 = Analog Control	See Figure 4
	R05 = RF Switched to Analog Control	See Figure 5
	___ = Digital Modulation Only	See Figure 6
FPS Trigger / Analog input	Units Configured With FPS, PPK: TTL Levels, Triggered on TTL Rising Edge. Units Configured With A05, R05: 0 to 5 Volts Analog.	
RF Output Power Per Channel " <u>Factory Set When Ordered</u> ":	<b>YY</b> = 50 watts nominal for 24, 27, and 41MHz units Adjustable from 12 to 50 watts.	
<u>Both Outputs Must Have 50 ohm Load</u>	*25 watts nominal for 68 and 80 MHz unit, Adjustable from 12 to 25 watts.	
Output Impedance:	50 ohms Nominal	
Shutter Output:	0.3 sec delay. Opens on fault. Capable of sinking 1 amp at 28 volts maximum.	
Supply Voltage Input	+28 VDC $\pm$ 1%	
Supply Current Input	6.5 A for 25 W /ch units 9.0 A for 50 W /ch units	
Operating Temperature	+10°C to +55°C	
Air Flow through Heat Sink	> 36 CFM (> 17 litres / second) @ 25°C	
<b><u>MAXIMUM RATINGS:</u></b>		
Supply Voltage:	30 volts DC maximum	
Power Output:	No DC Feedback allowed	
Storage Temperature:	-20°C to +85°C	

**CONNECTORS & MECHANICAL:**
Located on front panel

RF Output Connector:

BNC Female

Power Supply Connections:

 Vcc Solder Post  
 Return Ground Lug

**25PIN SUB D CONNECTOR PINOUT:**
Located on front panel See Detail A of Outline Drawing.

1	+5V	+5V output for external fault indicators, 75 mA available.
2 – 3	NC	No connection.
4	THERM RTN	Ground – to be used as a return for Both THERM and THERM 2.
5	THERM 2	Thermostat connection – driver enters a fault condition unless this is shorted to ground.
6	THERM	Thermostat connection – driver enters a fault condition unless this is shorted to ground.
7	DRV TEMP	Normally HIGH, goes LOW when the driver is in an overheat fault.
8	QS TEMP	Normally HIGH, goes LOW when no short present on THERM.
9	HVSWR	High VSWR fault, normally HIGH, goes LOW during fault.
10	LP	Low RF Power indicator, normally HIGH, goes LOW while driver output is below the Low RF Power threshold.
11	HP	High RF Power fault, normally HIGH, goes LOW during fault.
12	MOD IN ANALOG	Controls the output power level in A05 and R05 models
13	FAULT RESET	Pulse LOW to reset the driver from a fault condition. This line should not be held LOW or it will defeat some of the fault conditions.
14	FPS TRG	Triggers a suppression pulse on a RISING edge.
15	MOD IN FIXED	Turns the driver off for the duration set by the pulse width control.
16	MOD IN VARIABLE	Turns the driver off while this input is HIGH.
17	SYNC OUT	Outputs a signal synchronized to the modulation output.
18-19	NC	No connection.
20	SHUTTER	0.3 sec delay. Opens on fault. Capable of sinking 1 amps at 28 volts maximum.
21 -24	NC	No Connection
25	GND	Ground.

Note: Some Control Signals Shown on Outline Drawing are Not Available on Standard Units.

**INDICATORS:**
Located on front panel

Power	Power Indicator – The module has 28V applied on the DC connector.
Low Power	Faults after 0.3 second, power below LP Set Point. Resets on power adjusted above Set Point.
High Power	Faults when power above HP Set Point. Reset required after removing fault.
High VSWR	Faults when reflected power above VSWR Set Point. Reset required after removing fault.
QS Temp	Faults on open Thermostat. Resets on closed Thermostat. (Q-Switch below set temperature)
DRV Temp Driver	The internal temperature of the module has reached 60°C. The driver will remain in this fault condition until it cools down.

**ADJUSTMENTS:**
Located Inside Unit Through Holes in Module Top Cover

RF Power Level Adjustment	Adjusts the output RF Power.
LP Set Point	Adjusts the minimum power threshold. If the module's output goes below this set value, the low power warning light will turn on, but the driver will continue to output power. This is a warning, not a true fault condition.
HP Set Point	Adjusts the maximum power threshold for the module. If the output rises above this threshold, the module will cease output until it is reset.
VSWR Set Point	Adjusts the module's tolerance for a mismatched load connected to RF Out. If a mismatch is detected, the driver will cease outputting power until reset.
Pulse Width	Adjusts the length of time the driver outputs no RF energy after receiving a trigger. 1 $\mu$ s to 14 $\mu$ s.

The following adjustment is not used on units configured with FPS or PPK:

Threshold	Sets the point below which the analog voltage is ignored and the system output is shut off.
-----------	---

The following adjustments are not used on units configured with Analog Input (A05, R05):

FPS Start	Adjusts the initial power level of the first pulse.
FPS Slope	Adjusts how quickly the RF pulses return to their normal level after the FPS has been triggered. 20 $\mu$ s to 300 $\mu$ s.
FPS Window	Adjusts the duration of the suppression pulse cycle. 20 $\mu$ s to 300 $\mu$ s.

Note: Some Adjustments Shown on Outline Drawing are Not Available on Standard Units.

**RELATED DOCUMENTS:**

Modulation Modes:	FPS	PPK	A05	R05	___ Digital Mod. Only
Outline Drawing:	53D2079	53D2079	53D2079	53D2079	53D2079
Operating Manual:	51A19365	51A19366	51A19367	51A19368	

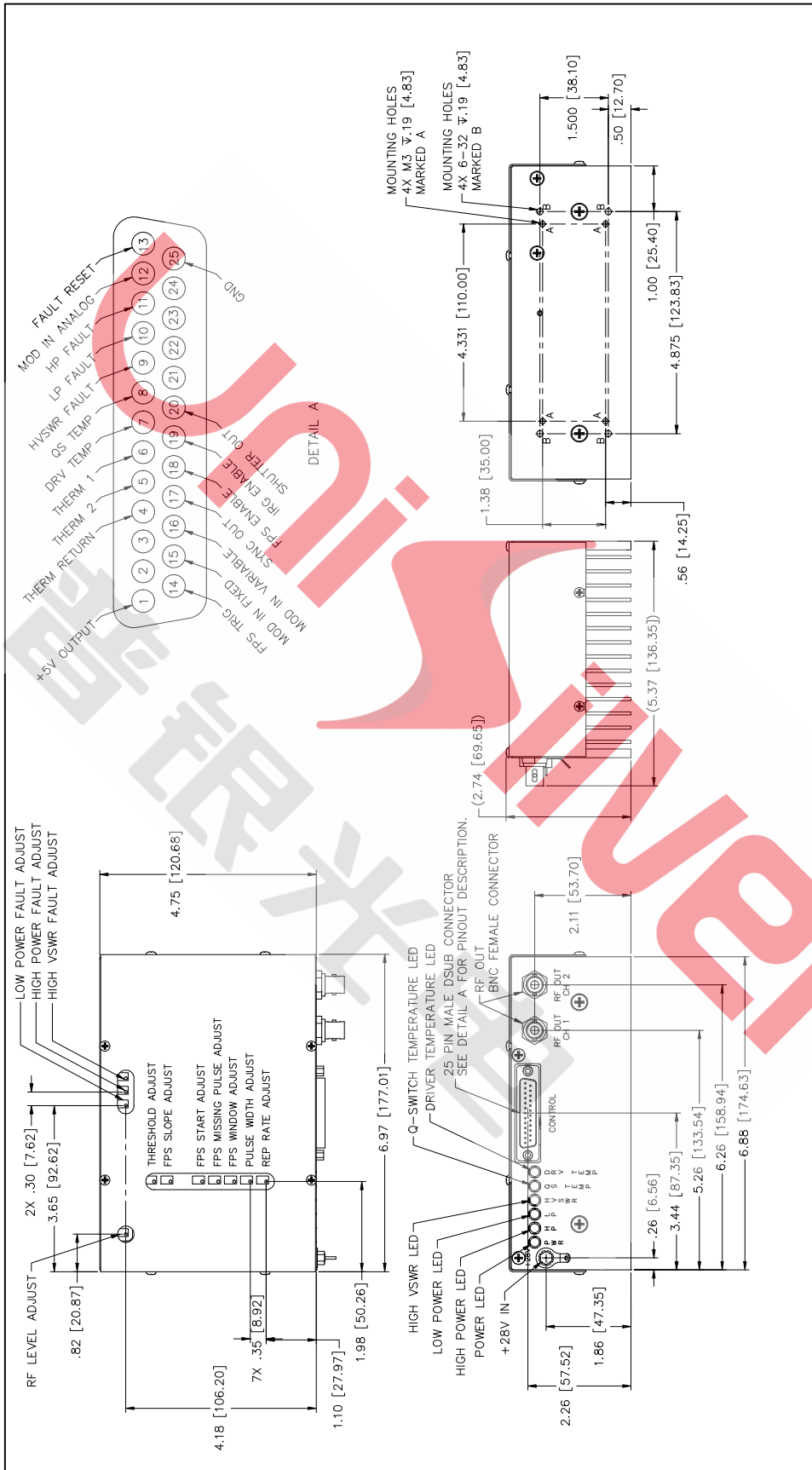

# Control Diagrams

Figure 2

## MQH0XX-YYDM-ZZZ-2S (HIGH POWER) First Pulse Suppression Control Connection and Control Diagrams

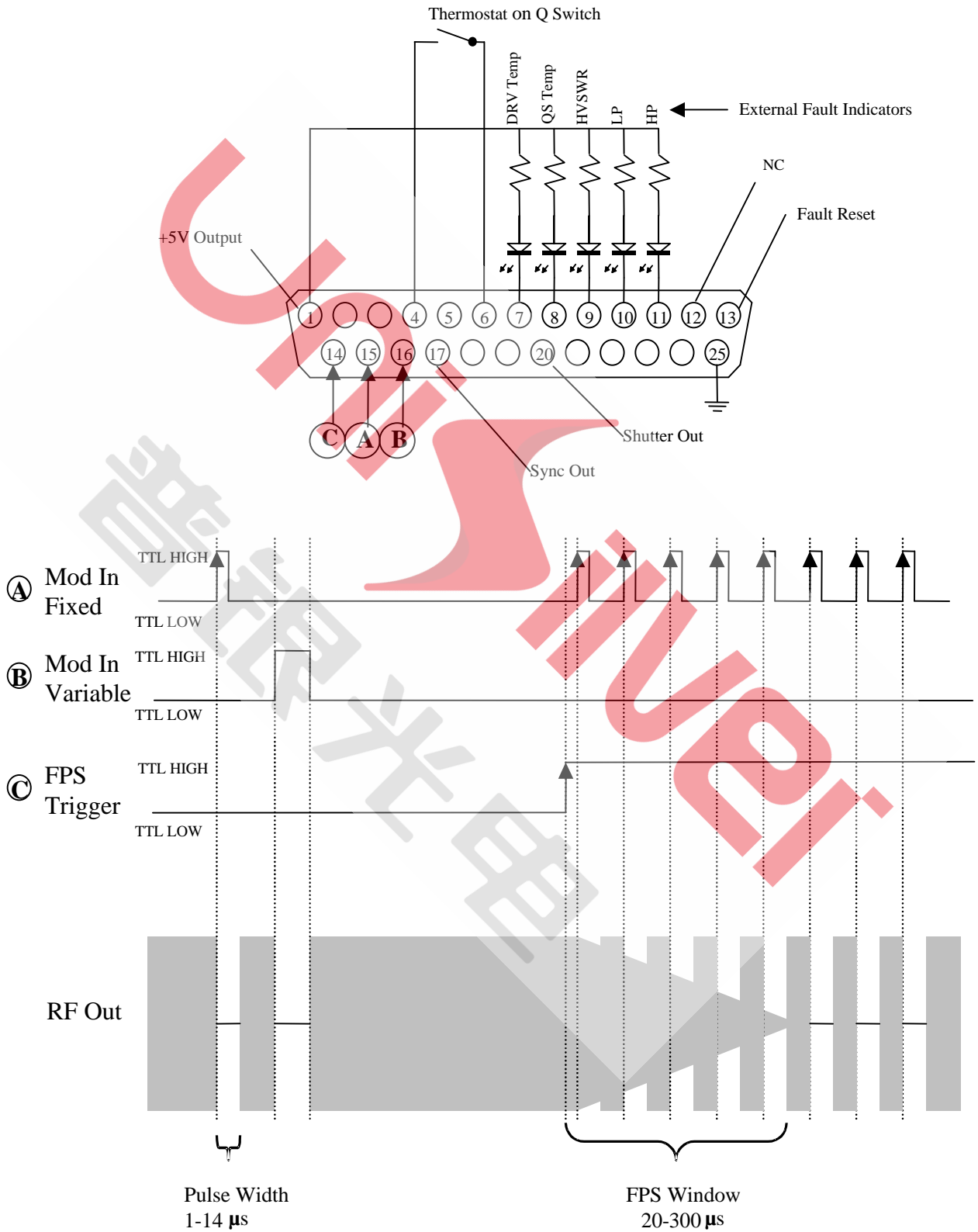
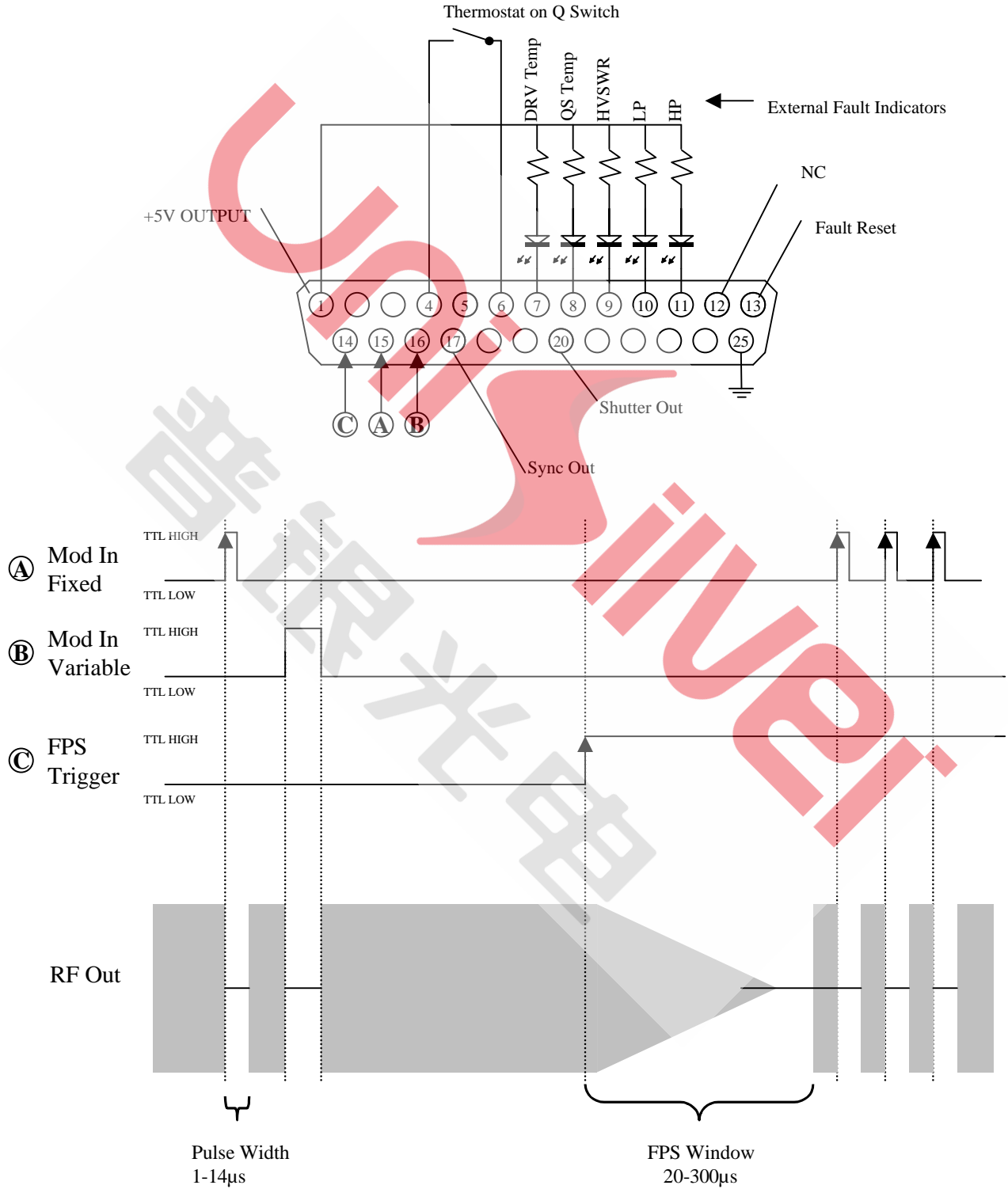
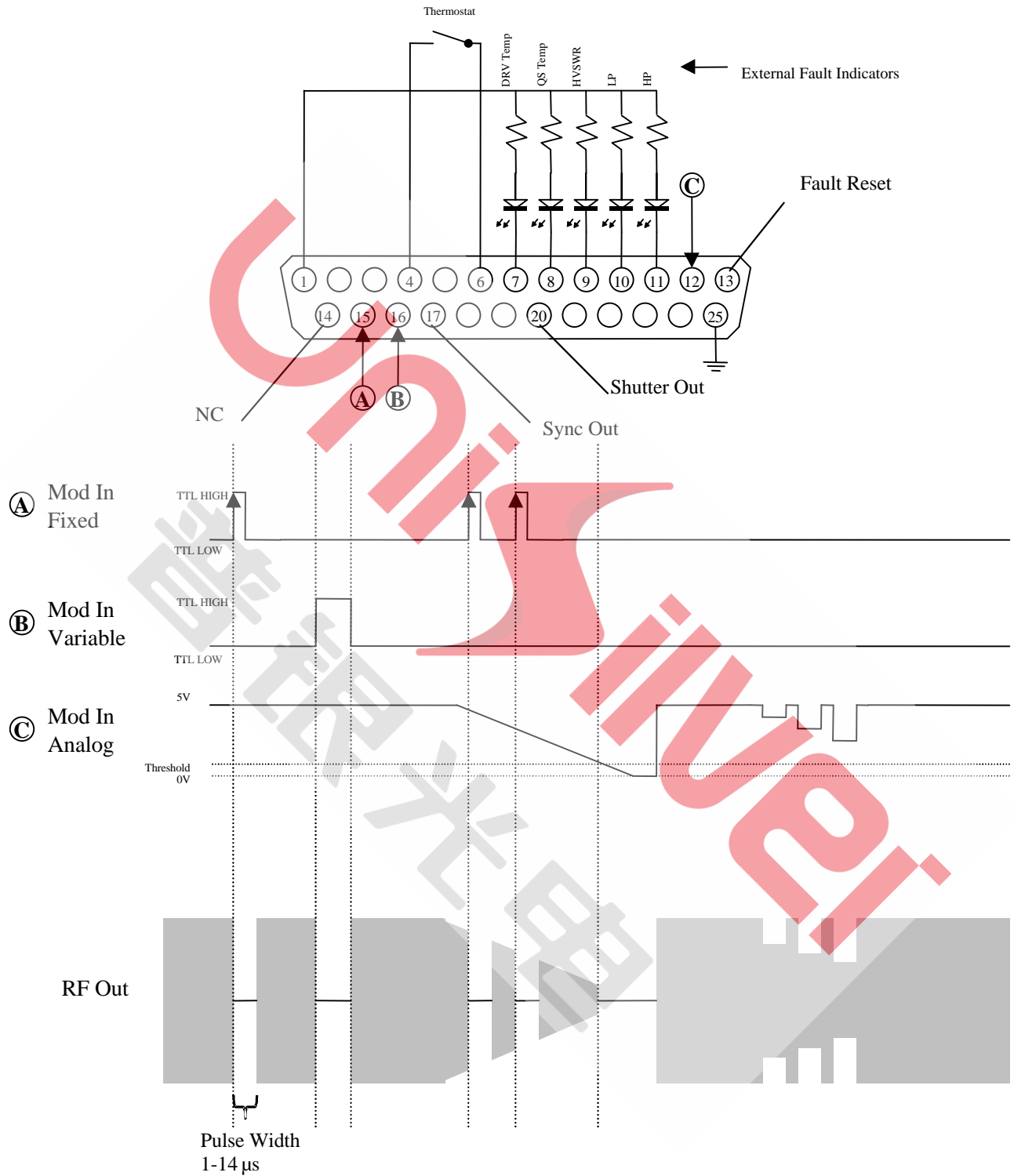

Figure 3

**MQH0XX-YYDM-ZZZ-2S (HIGH POWER) Pre-Pulse Kill Control**  
**Connection and Control diagrams**



**MQH0XX-YYDM-ZZZ-2S (HIGH POWER) Analog 5 Volt Control**  
**Connection and Control Diagrams**





**MQH0XX-YYDM-ZZZ-2S (HIGH POWER) RF Switch to Analog 5 Volt Control**  
**Connection and Control Diagrams**

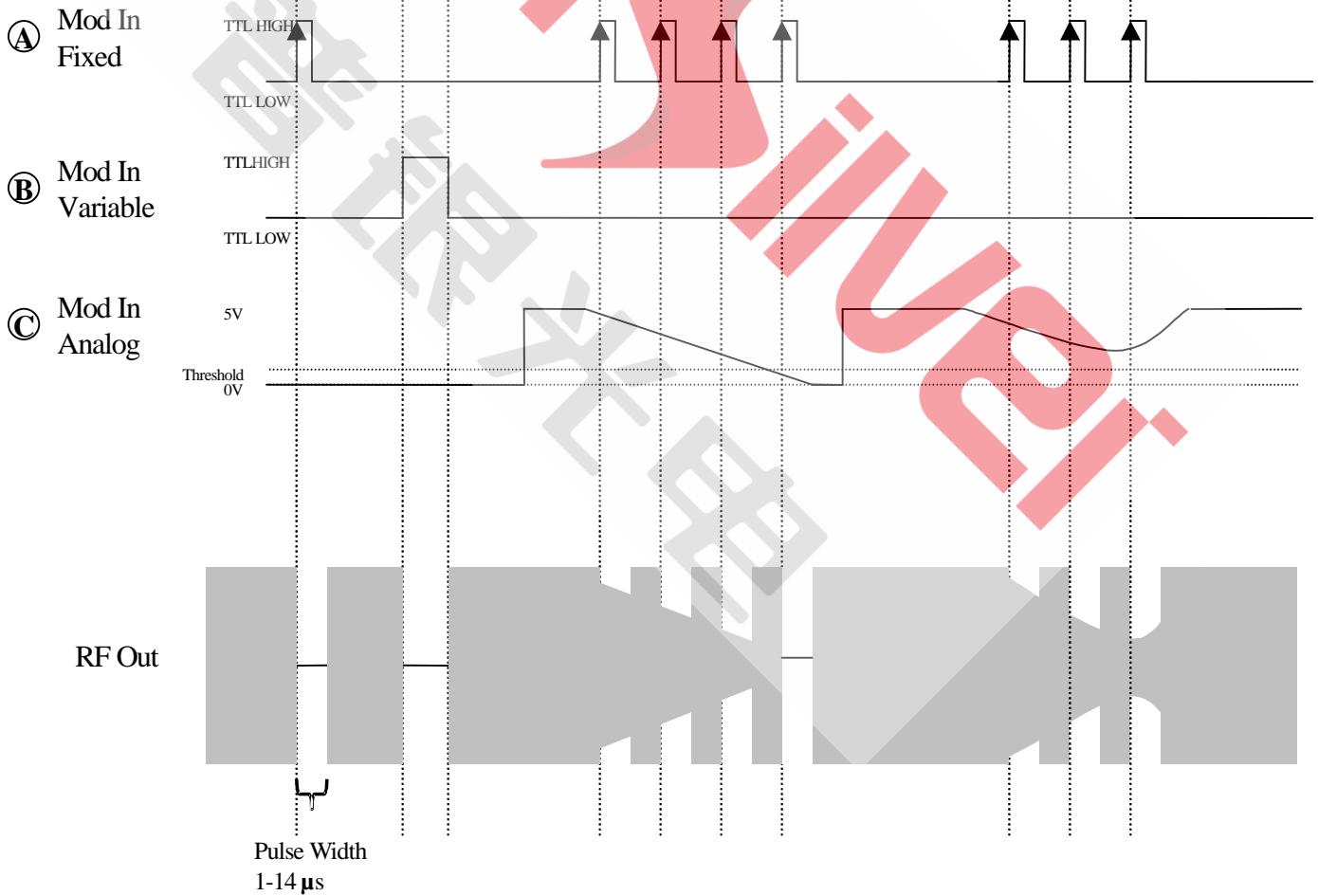
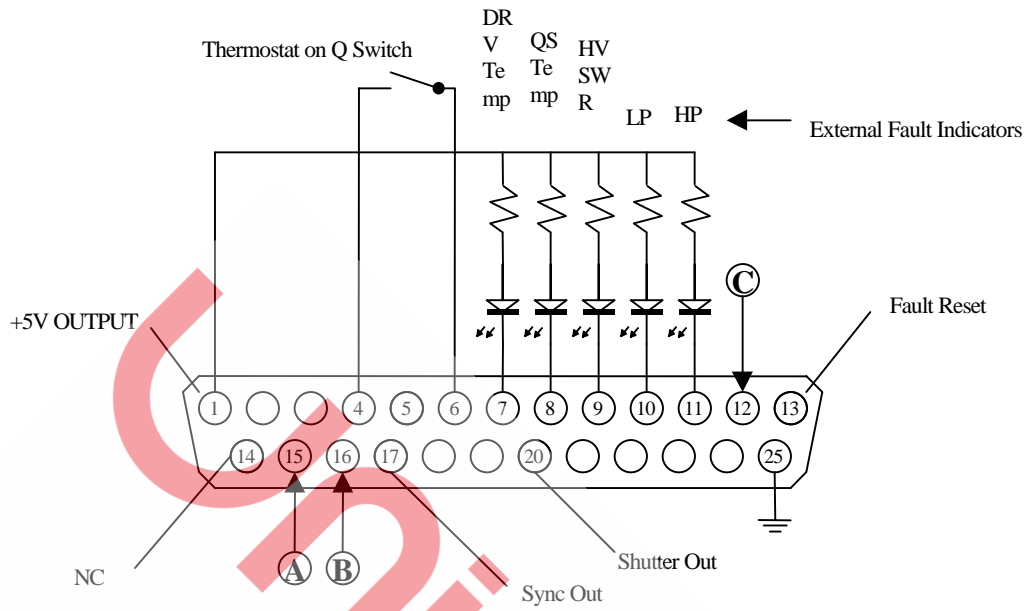

**MQH0XX-YYDM-ZZZ-2S (HIGH POWER) Digital Control Only**  
**Connection and Control Diagrams**

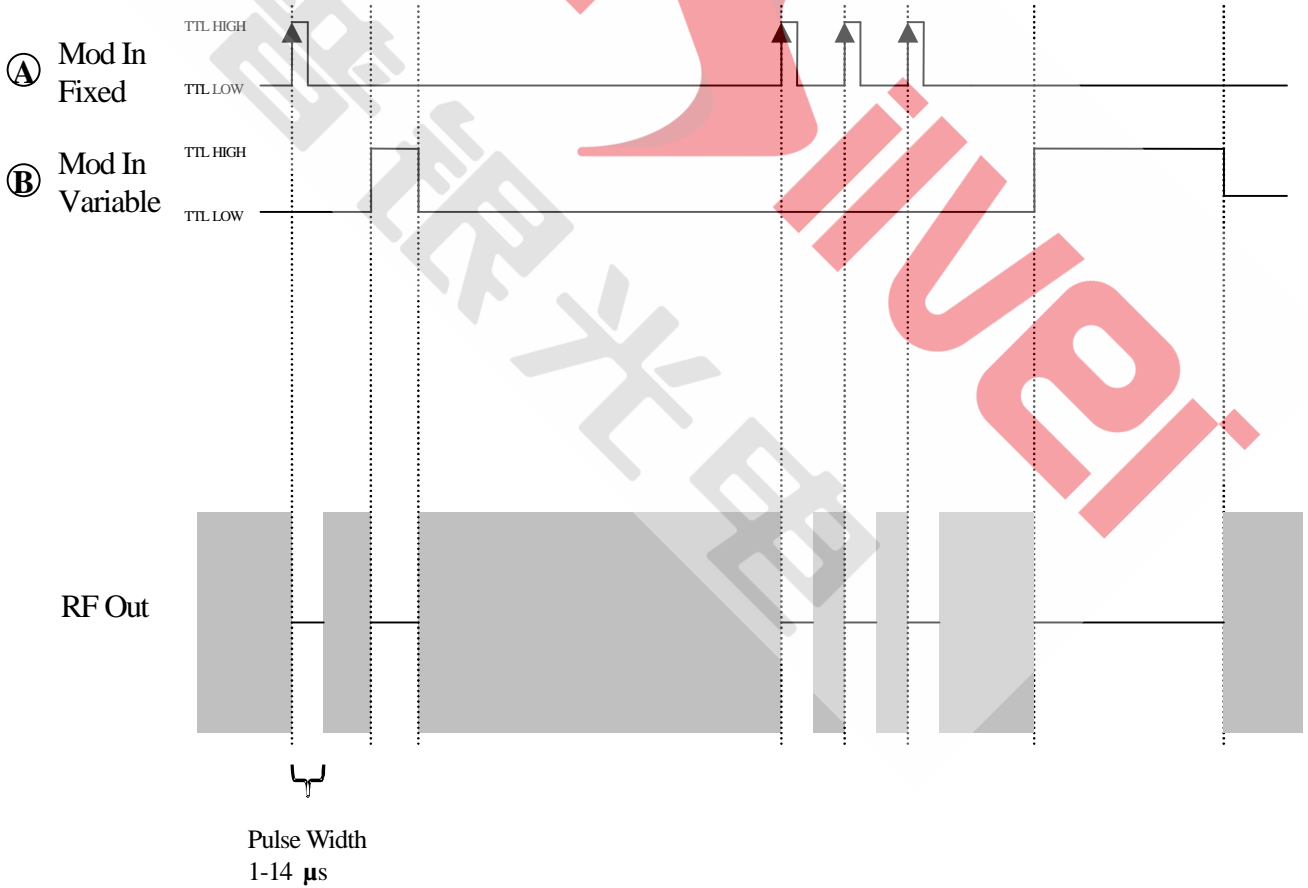
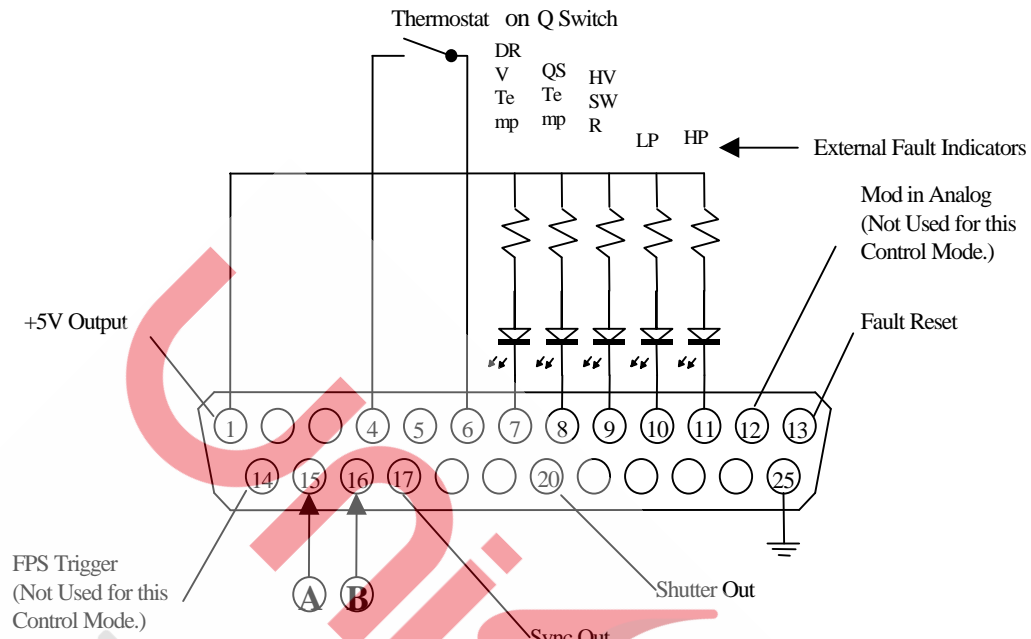

**Ordering Codes:**

Example: MQH027-50DM-A05-2S

A two channel 27 MHz RF Driver with two TTL Digital Modulation inputs (fixed and variable pulse width) and an analog input (A05) which enables control of the RF output power. Designed to Drive two AO Q-Switches requiring 50 watts RF Power or less per channel. Delivered as a RoHS compliant, forced air cooled OEM Module.

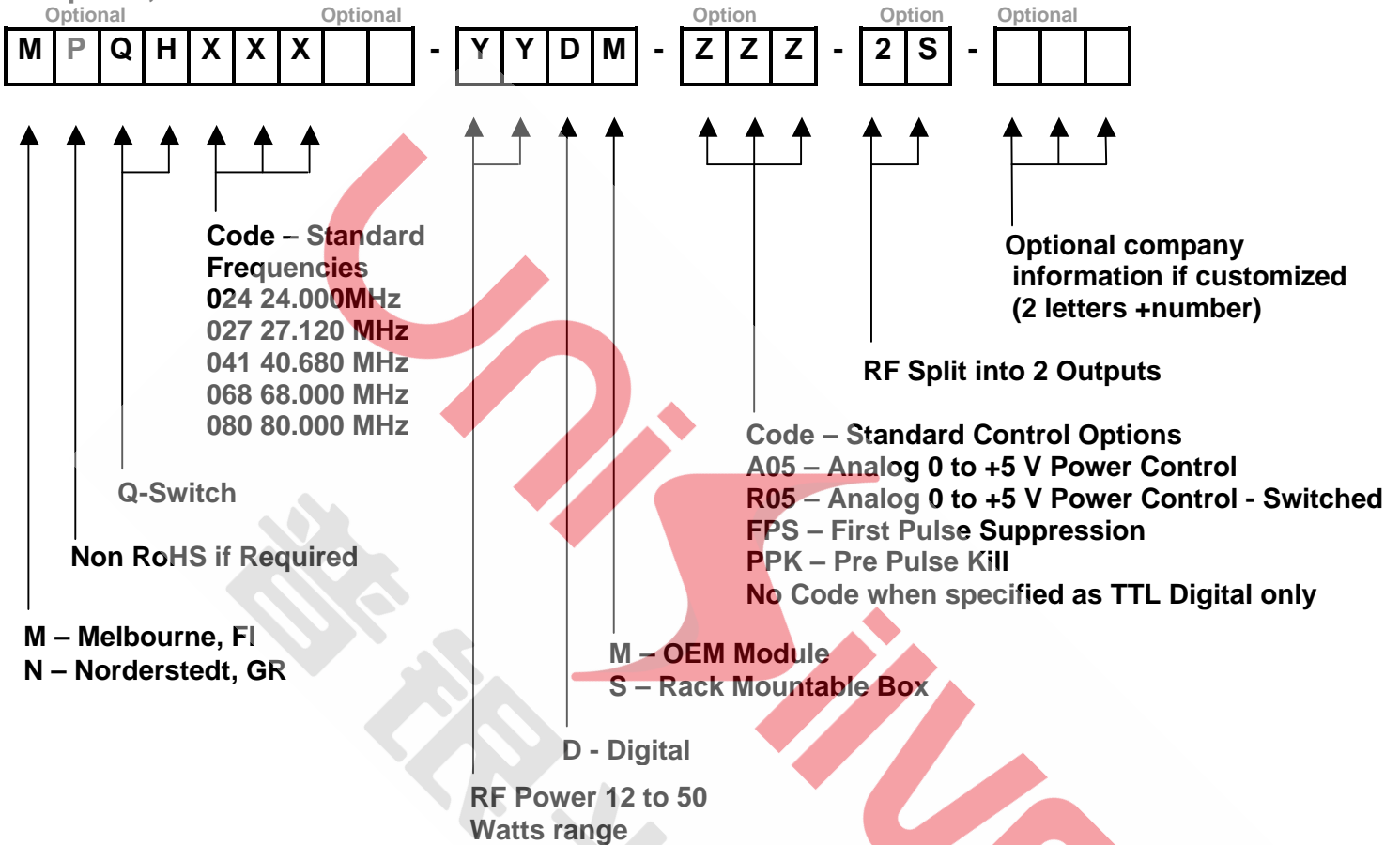
**Technical Assistance & Customization**

Our Engineering and Sales team are available to discuss your requirements and will assist you in selecting the most appropriate acousto-optic Q-Switch/ Diver combination for your laser.